



6HV Series Integrated solenoid valve (5/2, 5/3 way)

Compendium of 6HV Series

Multi-channel gas supply

When multi-valve is used (10 or more), both ends of the guide rail are equipped with an integrated inlet and exhaust module to prevent the gas supply pressure from dropping and causing malfunction.

Multi-series and Multi-port types are optional

6HV0500, 6HV100 series are optional ;
M5, 1/8" port size are optional.

Concentrated inlet and exhaust

Concentrated intake and exhaust, convenient piping, saving installation space.

Integrated inlet and exhaust module

The inlet and exhaust module adopts integrated aluminum alloy, which is beautiful and durable, and easy to disassemble.

Terminal

Special design for terminal, horizontal and vertical insertion can freely switch.

Integrated structure

The solenoid valve and the DIN rail are connected by a push-pull type, which can be integrated into the valve group with multiple valves. It is convenient and flexible to disassemble and replace.

Inner exhaust structure

Special structure in the valve body, which can collect pilot airflow, and then exhaust intensively from R, S port.

DIN standard rail

The guide rails conform to the DIN standard and are highly versatile. The relevant function module can be fixed to any position of the guide rail by stop screw.

Installation and Application(Solenoid valve)

1. Don't throw or drop the solenoid valve when take it, to avoid breaking valve;
2. Because solenoid pilot valve is sophisticated component, can't crash pilot valve by outside force, otherwise solenoid valve break possibly;
3. Don't dismantle solenoid valve freely, if the screw(M1.6X14) becomes loose, please tighten it by torque 0.1-0.12N.m;

4. About manual operation:

- 4.1. Ensure no danger, prior to activating manual override;

- 4.2. For push button option:

Activate by push the button in the direction shown

- 4.3. For slotted option:

Activate by push the button in the direction shown.

With correct size screw driver: please turn to lock gently(Torque : 0.1N.m).

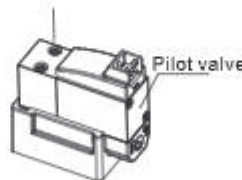

Attention



Normal position



Lucked position

- 4.4. Wiring instruction : Vertical plug type and parallel plug type are the same as plug, please insert wire line as up drawing by practicality.



Vertical plug wire



Parallel plug wire



6HV Series



Specification

Model	6HV0510	6HV0520	6HV0530	6HV110	6HV120	6HV130
Port size [Note1]	In=Out=M5			In=Out=M5(or=1/8")		
Orifice size(Cv)[Note4]	M5:3.4mm ² (0.2)	6HV0530CM5: 2.2mm ² (0.13)		06:8.9mm ² (0.52)	6HV130C06: 8.0mm ² (0.47)	
Max. frequency [Note2]	5 cycle/sec	3 cycle/sec	5 cycle/sec	3cycle/sec		
Fluid	Air(to be filtered by 40µm filter element)					
Acting	Pilot					
Operating pressure	6HV0530/6HV130 Othres		0.2~0.8MPa(29~114psi) 0.15~0.8MPa(21~114psi)			
Proof pressure	1.2MPa(175psi)					
Temperature	-20~70°C					
Material of body	Aluminum alloy					
Lubrication [Note3]	Not required					
Exhaust type of pilot valve	Main valve and pilot valve is centralized exhaust					

Symbol

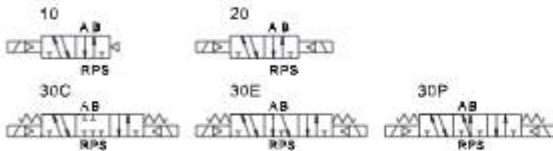

Product feature

1. Electrical entry is terminal, horizontal and vertical Insertion can freely switch.
2. Inner exhaust structure, which can collect pilot airflow, and then exhaust intensively from R, S port.
3. Internal hole adopts special processing technology which has little attrition friction, low start pressure and long service life.
4. The solenoid valve and the DIN rail are connected by a push-pull type, which can be integrated into the valve group with multiple valves. It is convenient and flexible to disassemble and replace.

Coil specification

Item	Specification			
Standard voltage	AC220V	AC110V	DC24V	DC12V
Scrop of voltage	AC : +15% ~-10%		DC : ±10%	
Power of consumption	1.1VA		0.7W	
Protection	Dustproof			
Temperature classification	F Class			
Electrical entry	Terminal			
Activating time	0.05 sec and below			

Ordering code(Solenoid valve)

6HV 1 10 06 B 050 □



① Model	6HV: 5 port 2(3) position solenoid valve				
② Code	05: 0500 Series	1: 100 Series			
③ Valve type	10 : Single solenoid(5/2 Way)	20 : Double solenoid(5/2 Way)	30C : Double solenoid(5/3 way closed center)		
	30E : Double solenoid(5/3 way Exhaust center)	30P : Double solenoid(5/3 way pressure center)			
④ Port size	M5: M5	M5: M5	06: 1/8"		
⑤ Voltage	A: AC220V		B: DC24V	C: AC110V	F: DC12V
⑥ Wire length	050: 0.5m		200: 2.0m		
⑦ Thread type	No this code	No this code	Blank : PT thread	G : G Thread	T : NPT Thread

Ordering code(DIN guide rail)

6HV 100M 6F



① Model	6HV: 5 port 2(3) position solenoid valve				
② Code	0500M: DIN guide rail for 0500 Series		100M: DIN guide rail for 100 Series		
③ Number of stations	4F: Manifold for 2, 3, 4 stations	4F: Manifold for 2, 3, 4 stations	20F: Manifold for 19, 20 stations		
	7F: Manifold for 5, 6, 7 stations	6F: Manifold for 5, 6 stations	22F: Manifold for 21, 22 stations		
	10F: Manifold for 8, 9, 10 stations	8F: Manifold for 7, 8 stations	24F: Manifold for 23, 24 stations		
	12F: Manifold for 11, 12 stations	10F: Manifold for 9, 10 stations			
	15F: Manifold for 13, 14, 15 stations	12F: Manifold for 11, 12 stations			
	18F: Manifold for 16, 17, 18 stations	14F: Manifold for 13, 14 stations			
	21F: Manifold for 19, 20, 21 stations	16F: Manifold for 15, 16 stations			
	24F: Manifold for 22, 23, 24 stations	18F: Manifold for 17, 18 stations			

[Note] DIN guide rail contents inlet and outlet module or end cover. The detail configuration is: ten and less stations configure one inlet and outlet module and one end cover, ten over stations config two inlet and outlet modules.

Integrated solenoid valve (5/2, 5/3 way)

6HV Series

Flow chart

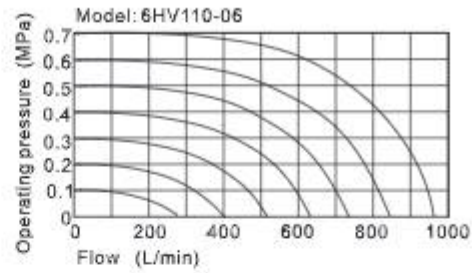
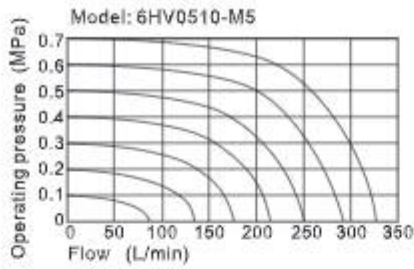

The data in flow rate chart are obtained from AirTAC lab.

Inner structure

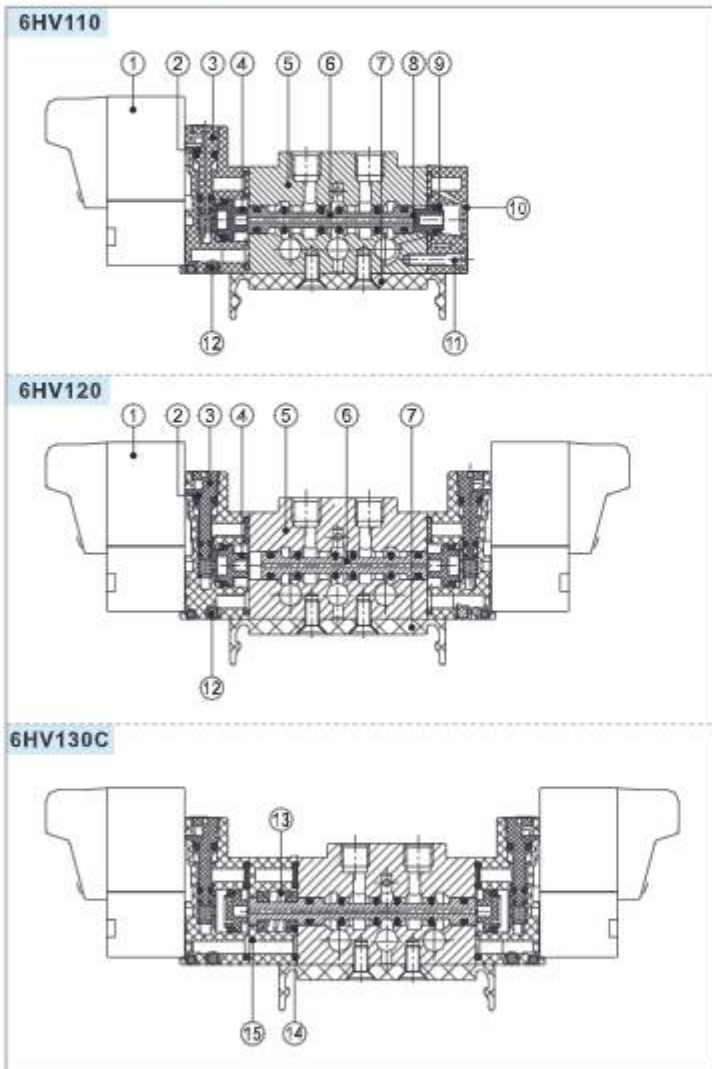

No.	Item	No.	Item	No.	Item
1	Pilot valve	6	Spool	11	Bolt
2	Manual override	7	Bracket	12	Steel ball
3	Pilot kit	8	Little piston	13	Spring
4	Big piston	9	Gasket	14	Return holder
5	Body	10	Bottom cover	15	Side cover

Integrated solenoid valve (5/2, 5/3 way)

6HV Series

Dimensions

6HV0500+6HV0500M2F~10F

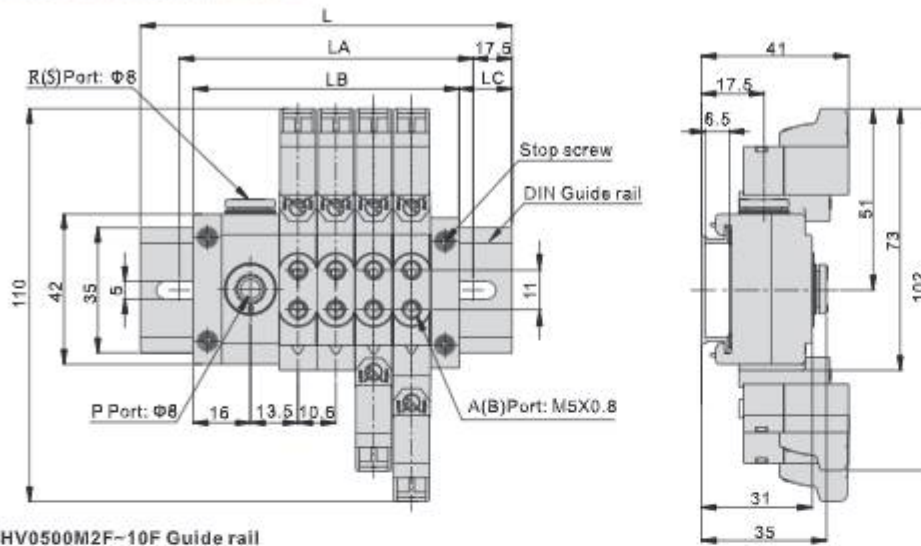

6HV0500M2F~10F Guide rail

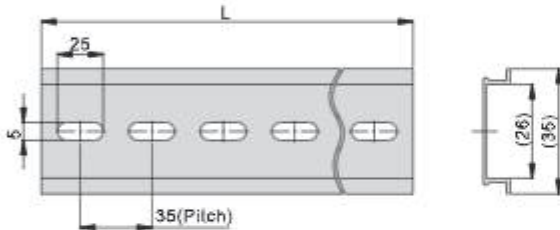

Item\Stations	2F	3F	4F	5F	6F
L	105	105	105	140	140
LA	70	70	70	105	105
LB	53	64	74.5	85	95.5
LC	26	20.5	15	27.5	22

Item\Stations	7F	8F	9F	10F
L	140	175	175	175
LA	105	140	140	140
LB	106	116	127.5	138
LC	17	29.5	23.8	18.5

6HV0500+6HV0500M11F~24F

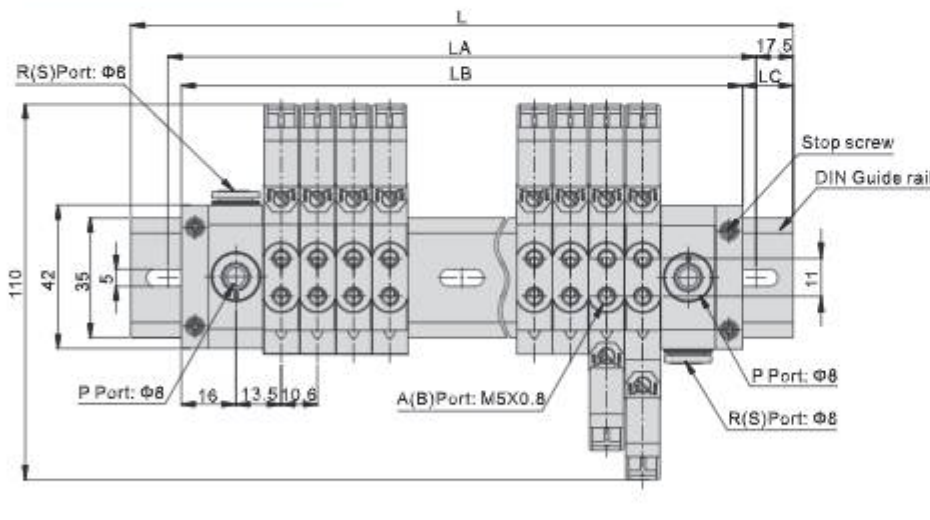

6HV0500M11F~24F Guide rail

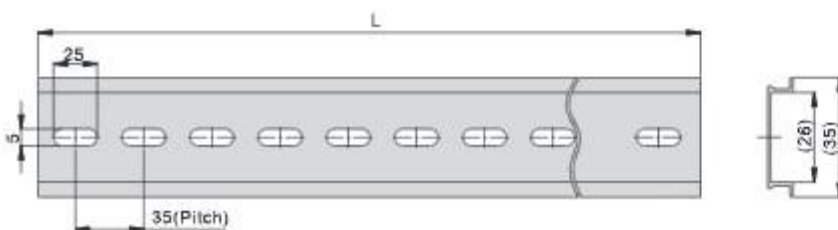

Item\Stations	11F	12F	13F	14F	15F	16F	17F
L	210	210	245	245	245	280	280
LA	175	175	210	210	210	245	245
LB	164.5	175	185.5	196.5	207	217.5	228
LC	23	17.5	30	24	19	31	26

Item\Stations	18F	19F	20F	21F	22F	23F	24F
L	280	315	315	315	350	350	350
LA	245	280	280	280	315	315	315
LB	238.5	249.5	260	270.5	281	292	302.5
LC	21	33	27.5	22	34.5	29	24

Integrated solenoid valve (5/2, 5/3 way)

6HV Series

6HV100+6HV100M2F-10F

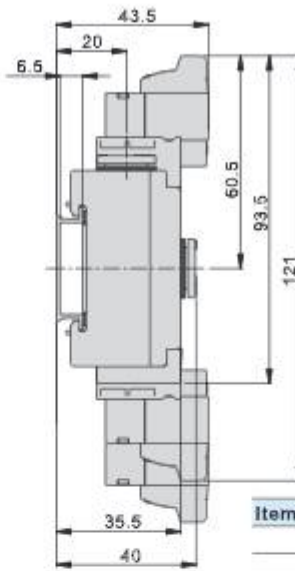
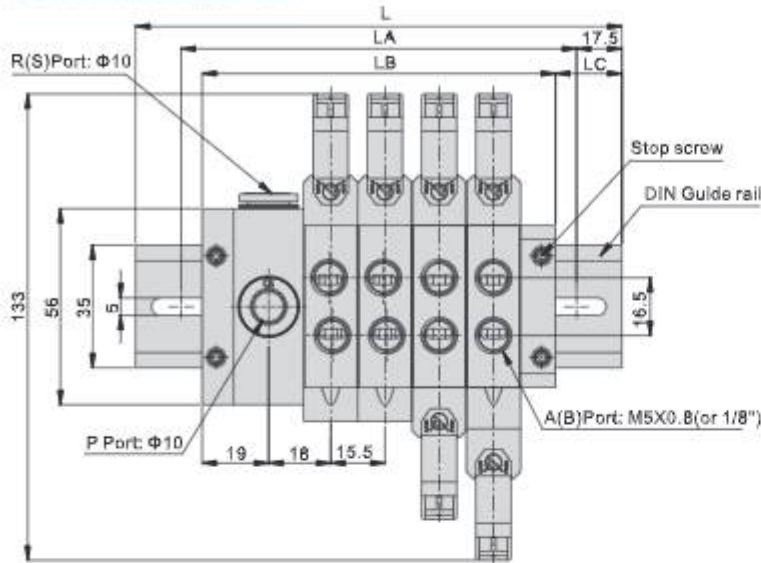

6HV100M2F-10F Guide rail

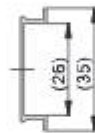
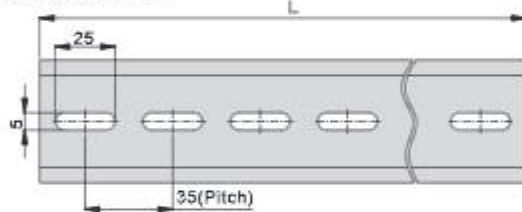

Item\Stations	2F	3F	4F	5F	6F
L	140	140	140	175	175
LA	105	105	105	140	140
LB	70	85.5	101	116.5	132
LC	35	27	19.5	29	21.5

Item\Stations	7F	8F	9F	10F
L	210	210	245	245
LA	175	175	210	210
LB	147.5	163	178.5	194
LC	31	23.5	33	25.5

6HV100+6HV100M11F-24F

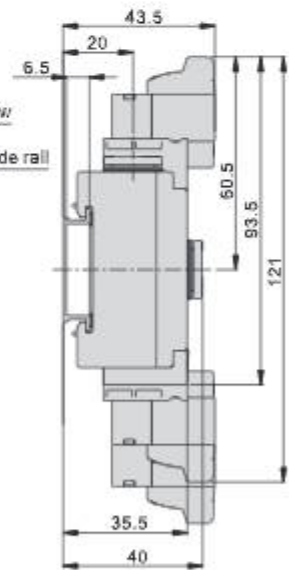
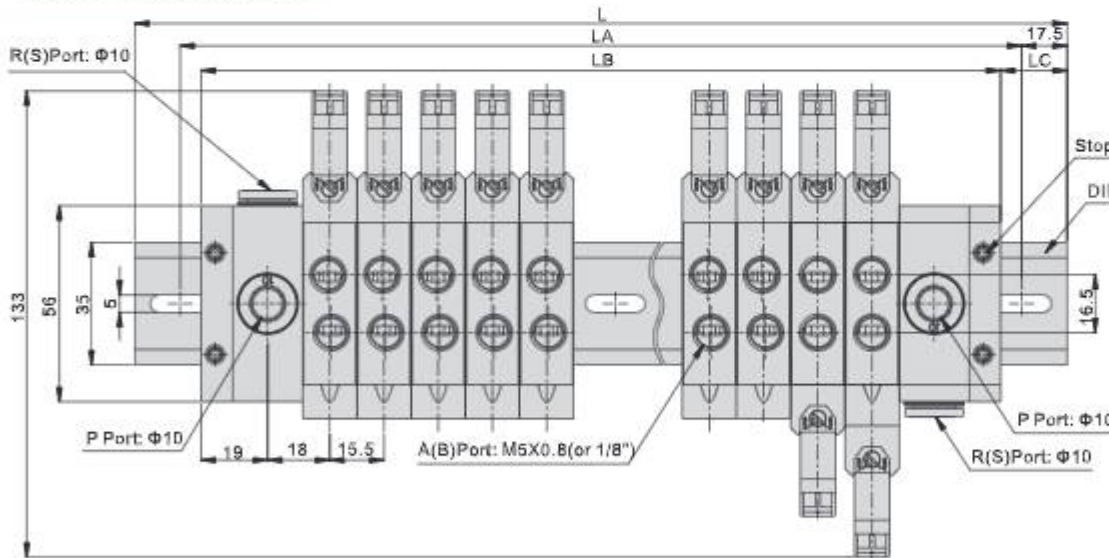

6HV100M11F-24F Guide rail

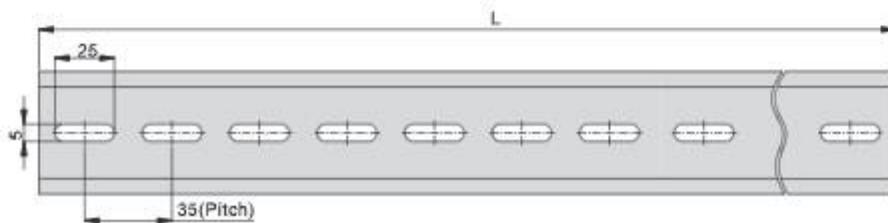

Item\Stations	11F	12F	13F	14F	15F	16F	17F
L	280	280	315	315	350	350	385
LA	245	245	280	280	315	315	350
LB	228.5	244	259.5	275	290.5	306	321.5
LC	28	18	28	20	30	22	32

Item\Stations	18F	19F	20F	21F	22F	23F	24F
L	385	420	420	455	455	490	490
LA	350	385	385	420	420	455	455
LB	337	352.5	368	383.5	399	414.5	430
LC	24	34	26	36	28	38	30

Installation and Application(Integrated Solenoid valve)

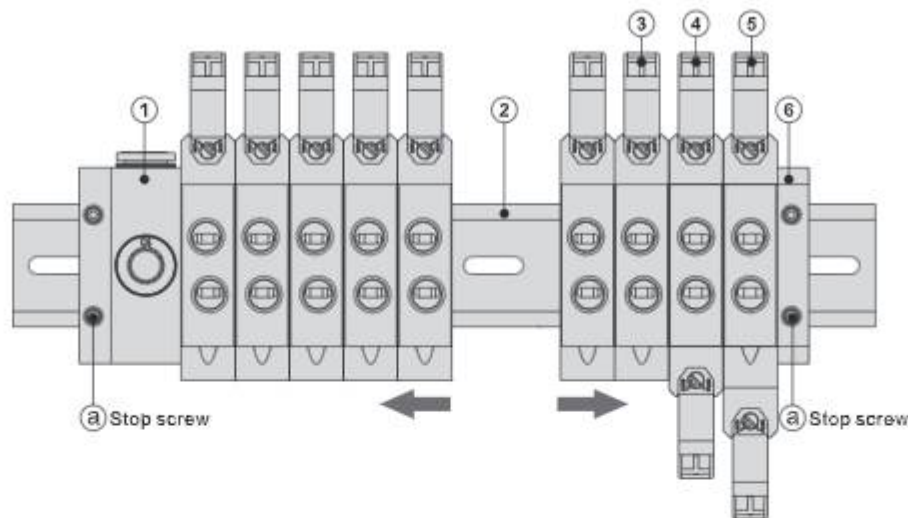

Configurations of integrated solenoid valve:

NO.	Name of module	How to order	Note
①	Inlet and outlet module	Contains in the DIN guide rail, can't be ordered independently	Left and right positions are interchangeable
②	DIN Guide rail	Refer to ordering code for detail	
③	Solenoid valve(Single solenoid(5/2 Way))	Refer to ordering code for detail	It can be installed at any position and can be added or removed at will.
④	Solenoid valve(Double solenoid(5/2 Way))	Refer to ordering code for detail	
⑤	Solenoid valve(5/3 Way)	Refer to ordering code for detail	
⑥	End cover	Contains in the DIN guide rail, can't be ordered independently	Left and right positions are interchangeable

- The integrated solenoid valve group is a highly integrated valve block consisting of a solenoid valve, an Inlet and outlet module, a end cover, and a DIN guide rail.
- Each functional module in the integrated solenoid valve group can be freely replaced, the number of stations can be increased or decreased according to demand.

3. The method of increasing stations:

① Loosen the stop screw. ②

② Separate the original solenoid valves that you wish to add.

③ The newly added solenoid valve is mounted on the DIN rail according to the "Fig. 1" method.

④ Push the other functional modules to make them tightly connected, then tighten the stop screws ② to complete the increasing stations.

4. Notice :

- Stop screw tightening torque : 6HV0500 : 1N.m/6HV100 : 1.4N.m.
 - Fastening method: first fix one end cover, then push each function module hard so that there is no gap between the valves, then tighten the stop screw at the other end.
 - When reassembling: If the connection between the valves and the tightening torque of the stop screw are insufficient, air leakage may occur. Before ventilating, please make sure there is no gap between the valves, and firmly fix it on the guide rail before venting.
5. The method of removing the solenoid valve from the DIN rail:
Refer to the requirements of "Fig. 2" for details.

